



**MR40**



100%  
made in  
ITALY



**4  
Ton**

Electronic  
Pc board



Foot protection  
microswitch



## MID RISE

### Extra low profile Lift for cars and duty vehicles

Electro-hydraulic extra low lift with a minimum height of only 120 mm from the ground, with a double platform and platforms connected to each other by a double torsion bar to obtain perfect synchronization and leveling.

- Double redundant hydraulic circuit consisting of 4 pistons, 2 on each platform
- Equipped with safety and shut-off valve on the hydraulic circuit for overload protection and hoses breaks
- Self-lubricating axle bearings on each rotating pin, no maintenance required
- High-sliding and self-lubricating polyethylene sliding pads.
- Lowering speed control with compensation valve
- "Hold to run" 24V Control.
- Electric Micro Switch with "foot guard" device and acoustic signal, to protect the last lowering travel
- Suitable for both floor and recessed installation, even under difficult conditions in case not available deep pits.



# MR40



Technological Innovation and Technical Support



Private Label Production or Color Customization



TUV and CE Certifications, Warranty



Customer Care, Pre-sale and after sales assistance

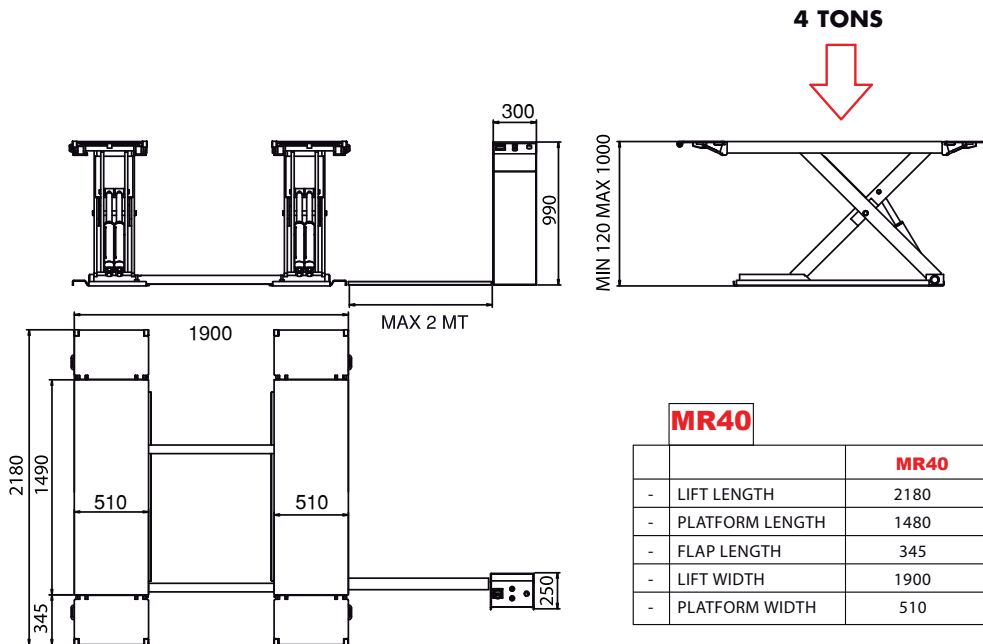

## Technical data

- Electro-hydraulic Control Unit in metal structure (without plastic parts)
- Capacity 4000 kg
- Standard Power Unit Kw 1,1 400V 3Ph 50Hz
- Total Weight 650kg
- Lifting height min 120mm max 1000 mm
- Up-Down Travel speed 20/20sec
- Equipped with 4 flap run-up ramps
- Hoses covered with anti-blastsheath
- Kit of 4 rubber pads 20mm

## Optional

- Rubber pads 40mm
- Rubber pads 60mm
- Additional ramps for low-floor vehicles
- Kit for built-in central cover
- Kit for recessed frame
- Kit for built-in slides for horizontal standing ramps position
- Hose extension
- Additional cross bars for vehicles
- Single-Phasemotor
- Basement and-or platform hot deep galvanized
- Ral colors on request